

# Southwest Clean Air Agency

11815 NE 99<sup>th</sup> Street, Suite 1294, Vancouver, WA 98682-2322 Voice: (360) 574-3058 Fax: (360) 576-0925

## CYCLONE SEPARATORS & PNEUMATIC TRANSFER EQUIPMENT

(Instructions on Back)

APPLICANT: \_\_\_\_\_ NOC# \_\_\_\_\_

### CYCLONE DATA:

Manufacturer: \_\_\_\_\_

Model Number: \_\_\_\_\_ Identification Used at Plant: \_\_\_\_\_

Main Plenum Size: \_\_\_\_\_ Main Plenum Length: \_\_\_\_\_

Number of Pickup Points: \_\_\_\_\_ Inlet Concentration: \_\_\_\_\_ Outlet Concentration: \_\_\_\_\_

Equipment is used for:  material transfer or  discharge control equipment.

Pressure monitoring device - Manufacturer: \_\_\_\_\_ Range: \_\_\_\_\_ Normal: \_\_\_\_\_

Is there an airlock?  yes  no Expected material catch (tons/year)? \_\_\_\_\_

Is there additional control equipment?  no  yes If yes, attach separate data sheet.

Emissions Discharge: Concentration \_\_\_\_\_ gr/dscf Quantity: \_\_\_\_\_ tons per year

### FAN DATA:

Inlet Duct Size: \_\_\_\_\_ Outlet Duct Size: \_\_\_\_\_

Blade Diameter: \_\_\_\_\_ Blade Width: \_\_\_\_\_ Blade RPM: \_\_\_\_\_

Normal Operating Parameters: CFM: \_\_\_\_\_ Static Pressure Rise: \_\_\_\_\_

Manufacturer: \_\_\_\_\_ Model Number: \_\_\_\_\_ Voltage: \_\_\_\_\_

### DRIVE DATA:

Horsepower: \_\_\_\_\_ RPM: \_\_\_\_\_ Speed Ratio: \_\_\_\_\_

### CYCLONE DIMENSIONS:

D \_\_\_\_\_ (or L x W if rectangular)

d1 \_\_\_\_\_ (or L x W if rectangular)

d2 \_\_\_\_\_ (or L x W if rectangular)

d3 \_\_\_\_\_ (or L x W if rectangular)

H1 \_\_\_\_\_

H2 \_\_\_\_\_

H3 \_\_\_\_\_

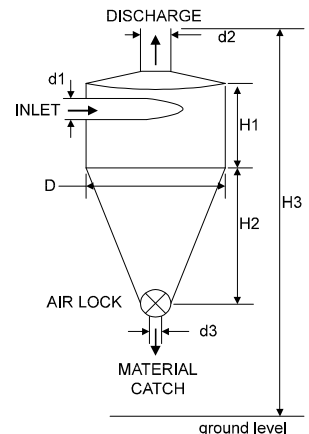

## **INSTRUCTIONS FOR CYCLONE SEPARATORS & PNEUMATIC TRANSFER EQUIPMENT**

Use of this form will assist in review and approval for equipment or processes utilizing a cyclone separator to collect particulate matter emissions or as a pneumatic transfer device. The information requested on the reverse side of this form is necessary for SWCAA to evaluate whether your proposal can comply with federal, state, and local requirements. It does not necessarily mean the Notice of Construction (NOC) will be approved as submitted. Your NOC will be approved or denied only after submittal and evaluation of all required information. However, the time required to evaluate your application will be significantly shortened if the information you submit is complete.

### General Information to be Submitted

1. A general Notice of Construction cover sheet should accompany all applications.
2. The concentration of particulate matter should be identified for both the inlet and discharge points.
3. The particulate matter should be evaluated to determine if it is a toxic as identified in WAC 173-460 "Controls for New Sources of Toxic Air Pollutants".
4. The maximum flow rates of the contaminated air streams in standard cubic feet per minute. Provide the basis or source of this information.
5. Drawings to show the location of the blower, duct system, location of cyclone, distance to property boundaries and other control equipment such as baghouses or other discharge points.
6. Calculations to show how the blower and cyclone were sized to deliver the amount of flow required in the system.
7. A process and instrumentation diagram for the process stream showing the types and locations of meters, gauges, feedback controllers, regulators and recorders, etc. as applicable.
8. A plot plan showing the location and neighborhood of the proposed project including distance to adjacent property lines and elevation of discharge stack.
9. A copy of the Operations and Maintenance (O&M) Manual for all control equipment.
10. The method of indicating and recording hours of operation.
11. A copy of the fan curve for the blower or fan.
12. A description of the use of the cyclone, the operational characteristics such as intermittent or full time, any particle size distribution of the contaminants in the air stream, and a verbal distinction between air flow and material flow in cfm or quantity handled.